

Multi-Movement Pendant Installation Instructions

General Safety Instructions

To the installer!

Please read these installation instructions very carefully and observe the safety instructions and specifications for installation.

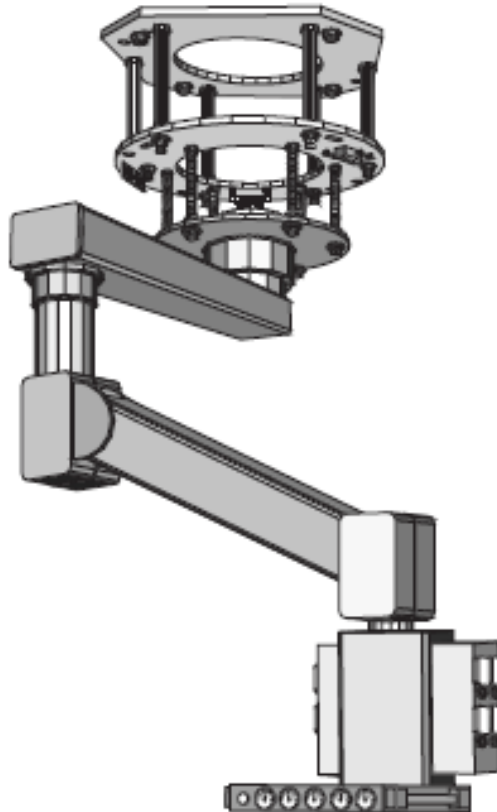

www.precisionuk.co.uk



Company Registered Office: Crown House, Stockport, Cheshire, SK1 3RB
Registered in England and Wales No. 05058855
VAT No. 850 0700 67

CPX Technology Building, Pepper Road, Hazel Grove,
Stockport, Cheshire, SK7 5BW, UK
Tel: +44 (0) 161 487 2822
Fax: +44 (0) 161 487 2816
Email: info@precisionuk.co.uk

Installation Instructions

3 Interface plate

When installing the interface plate, its alignment (top, bottom side and gas supply) in the room must be observed.

Install additional connection blocks on the interface plate for low voltage, video and communication cables, as shown on the order-based configuration sheet.

Table of Contents

3.1 Installation of single interface plate

3.2 Prepare installation of single interface flange

Packing list interface plate "Single"

- 1 interface plate single - weight 16,5 kg equipped with:
- connection set
- traction relief
- earth rail
- fasting gib for NIST connectors

Accessories required for installation:

- 6 thread bolts M 16 x 330 mm
- 6 washers
- 6 spring washers
- 6 hexagon nuts M 16

www.precisionuk.co.uk



Company Registered Office: Crown House, Stockport, Cheshire, SK1 3RB
Registered in England and Wales No. 05058855
VAT No. 850 0700 67

CPX Technology Building, Pepper Road, Hazel Grove,
Stockport, Cheshire, SK7 5BW, UK
Tel: +44 (0) 161 487 2822
Fax: +44 (0) 161 487 2816
Email: info@precisionuk.co.uk

3.1 Installation of interface plate

Fig. 3.1

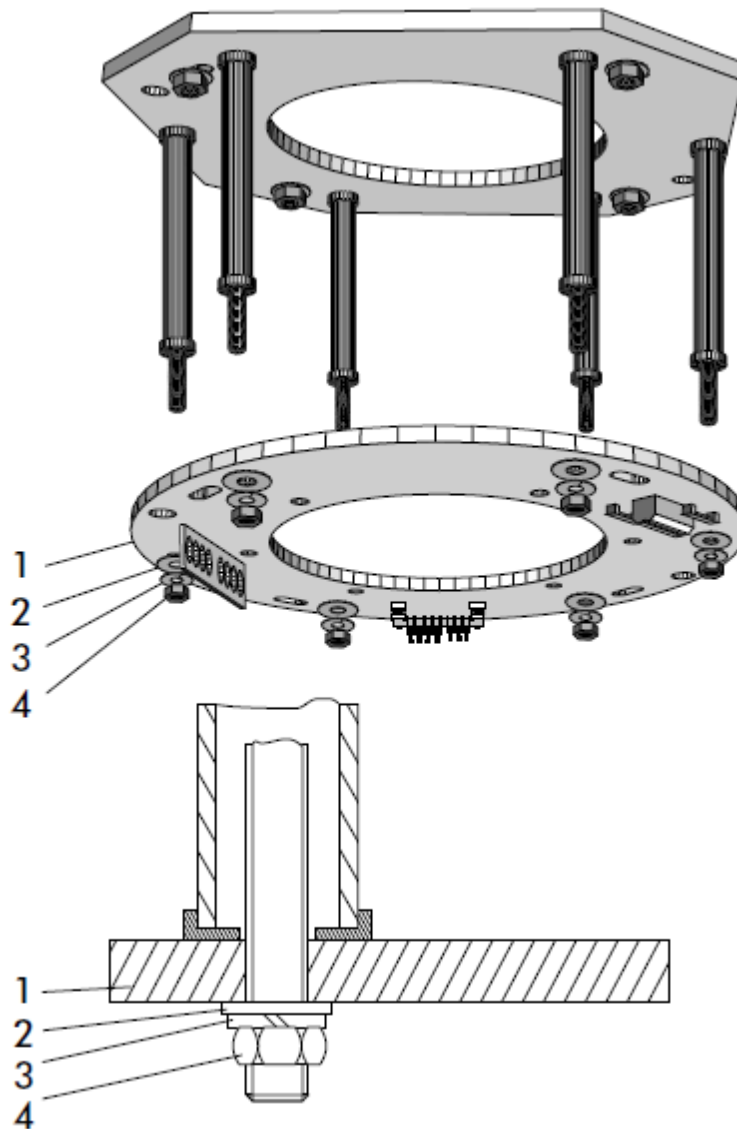

DANGER:

Falling interface plates can result in severe injuries. During assembly no people are allowed under the interface plate!

Indication:

The interface plate must be aligned according to the gas supply on site.

Instructions

1. Fix the **interface plate (1)** with **washer (2)**, lock **washer (3)** and **hexagon nut (4)** at the ceiling plate and tighten them with a force of 100Nm.

DANGER:

If the hexagon nuts (4) are not correctly tightened, the supporting bracket system may fall down. Tighten the nuts (4) with 100Nm.

2. Use a torque wrench to tighten the hexagon nuts with 100Nm.

www.precisionuk.co.uk



CPX Technology Building, Pepper Road, Hazel Grove,
Stockport, Cheshire, SK7 5BW, UK
Tel: +44 (0) 161 487 2822
Fax: +44 (0) 161 487 2816
Email: info@precisionuk.co.uk



Company Registered Office: Crown House, Stockport, Cheshire, SK1 3RB
Registered in England and Wales No. 05058855
VAT No. 850 0700 67

3.2 Preparing installation of flange

Fig. 3.2

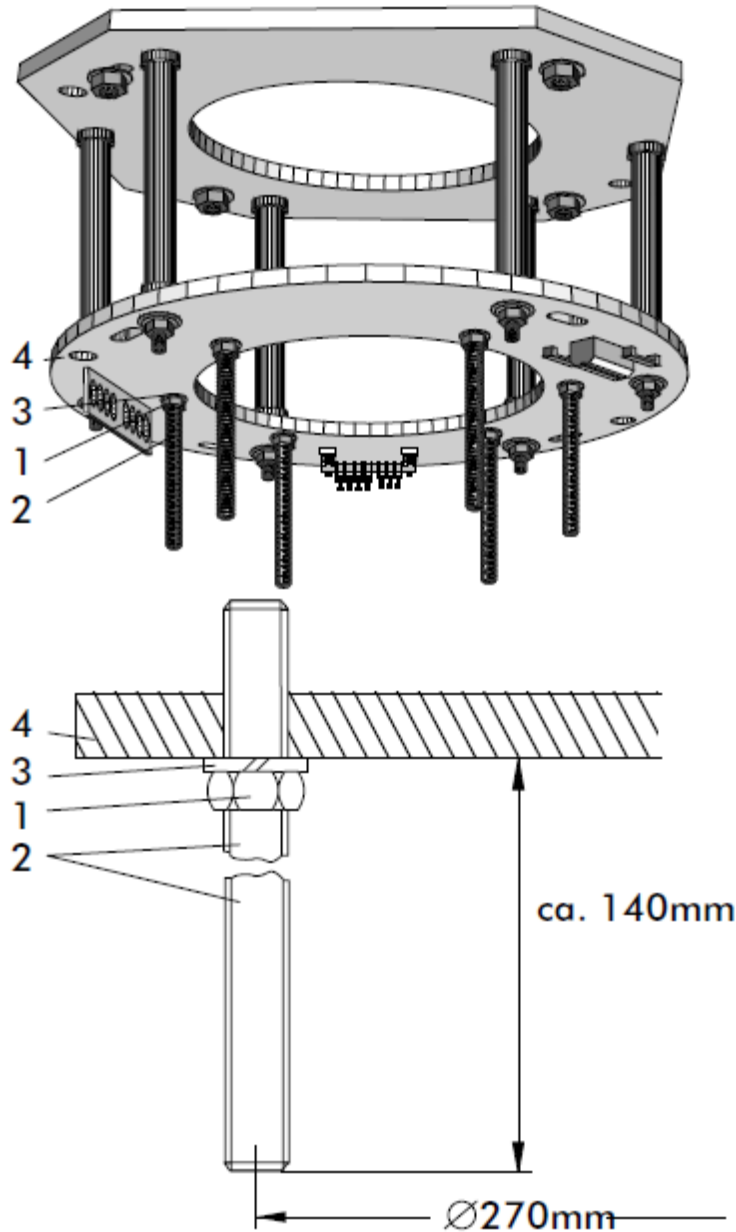

DANGER:

Because of reasons of physical strength, the thread bolts should not exceed a length of 330mm.

DANGER:

If the interface plate is installed at a raw ceiling, the supporting bracket system may fall down, if the threaded bolts are not tightly screwed in. Therefore completely screw them into the interface plate.

1. Screw **hexagon nut (1)** on the **thread bolts (2)** and apply lock **washer (3)**.

www.precisionuk.co.uk



CPX Technology Building, Pepper Road, Hazel Grove,
Stockport, Cheshire, SK7 5BW, UK
Tel: +44 (0) 161 487 2822
Fax: +44 (0) 161 487 2816
Email: info@precisionuk.co.uk



Company Registered Office: Crown House, Stockport, Cheshire, SK1 3RB
Registered in England and Wales No. 05058855
VAT No. 850 0700 67

DANGER:

If the hexagon nuts are not correctly tightened, the supporting bracket system may fall down. Tighten the nuts with 100Nm.

2. Screw the thread bolts in such a way into the **interface plate (4)**, that later the flange plate is closely connected with the intermediate ceiling; then tighten with 100Nm. A guideline for adjustment would be approx. 140 mm.

Installation Instructions

4 Set of gas-interface

The set of gas interface consists of complete ball valves and a copper tube with 15 mm dia. with reducing bushing for connection of exhaust air and exhaust narcosis gas. Without aspiration the copper tube and reducing bushing are superfluous.

On the next pages installation of the single-interface plate is described. Installation is identical with Duo interface plate.

Table of Contents

4.1 Installation

4.1.2 Exhaust of air and narcosis gas

Packing list set of gas interface

The scope of delivery may vary, depending on the order.

Accessories required for assembly:

- 1 copper tube \varnothing 15mm

4 Set of gas interface

4.1 Installation

4.1.1 NIST Connectors *Fig. 4.1*

NIST Connectors

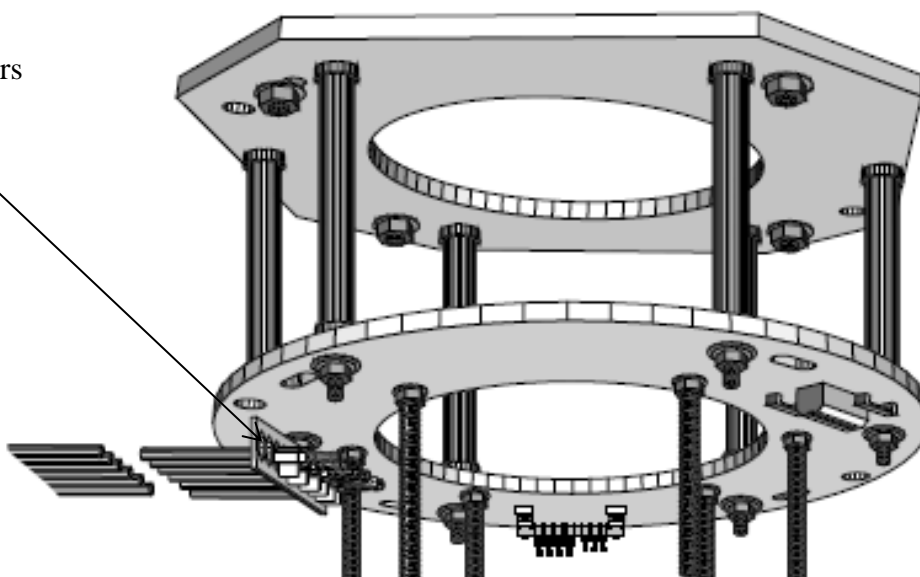

www.precisionuk.co.uk



CPX Technology Building, Pepper Road, Hazel Grove,
Stockport, Cheshire, SK7 5BW, UK

Tel: +44 (0) 161 487 2822

Fax: +44 (0) 161 487 2816

Email: info@precisionuk.co.uk



Company Registered Office: Crown House, Stockport, Cheshire, SK1 3RB
Registered in England and Wales No. 05058855
VAT No. 850 0700 67

INDICATION:

The gas supply points on the console of the interface plate can be supplied as shown in table 1.

Table 1 – Gas Supply		
Delivery Gas	Connection	Maximum No. Off
O2	Hexagon NIST Connector	3
N2O	Hexagon NIST Connector	3
O2/N2O	Hexagon NIST Connector	3
MA4	Hexagon NIST Connector	3
SA7	Hexagon NIST Connector	1
Vacuum	Hexagon NIST Connector	2
CO2	Hexagon NIST Connector	3
AGSS	Hexagon NIST Connector	1

In exceptional cases, after having consulted the responsible person for gas supply more outlets may be made available.

4.1.2 Air and AGSS

Fig. 4.2

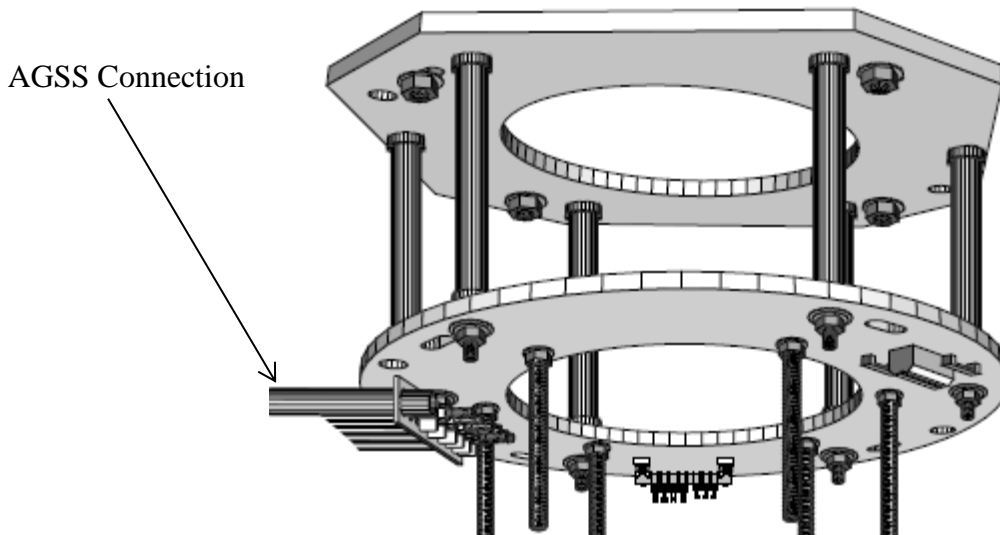

1. Guide enclosed **reducing ring** over the exhaust tube, resp. the AGSS connection **with $\varnothing 15\text{ mm}$** .
2. Insert the tube with reducing ring into the **bracket** and secure it with **threaded pin**